

SIGMA - your fitting choice

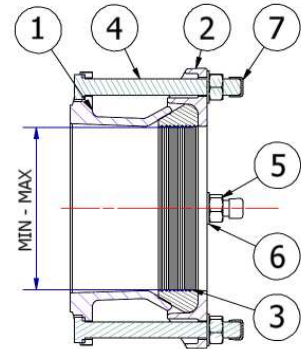

W - Range Flange Adaptors



Materials & Coatings

W - Range Flange Adaptors - Parts List

ITEM	DESCRIPTION	MATERIAL	SPECIFICATION
1	BODY CASTING	420/12 CAST S.G.IRON	WRAS APPROVED POWDER COATING
2	END RING CASTING	420/12 CAST S.G.IRON	WRAS APPROVED POWDER COATING
3	GASKET	EPDM ELASTOMER	EPDM ELASTOMER TO B.S.6920
4	ADJUSTING BOLT	GRADE 8.8 STEEL	DACROMATE PLATED
5	HEXAGON NUT	HEXAGONAL NUT	DACROMATE PLATED
6	WASHER	FLAT WASHER	DACROMATE PLATED
7	THREAD CAP	NYLON MOULDING	NATURAL FINISH

W - Range - RANGE DIMENSIONS

MODEL No.	DN	MIN O/D	MAX O/D	No. BOLTS & SIZE	WGT (kg)
F-50-1	50	59	72	2 X M12 X 110 LONG	3.30
F-65-1	65	72	85	2 X M12 X 115 LONG	3.80
F-80-1	80	88	103	4 X M12 X 115 LONG	4.80
F-100-1	100	105	122	4 X M12 X 115 LONG	4.90
F-100-2	100	109	128	4 X M12 X 115 LONG	4.90
F-125-1	125	125	140	4 X M12 X 115 LONG	5.50
F-125-2	125	132	146	4 X M12 X 115 LONG	6.75
F-125-3	125	138	153	4 X M12 X 115 LONG	6.75
F-150-1	150	155	175	4 X M12 X 115 LONG	7.50
F-150-2	150	159	182	4 X M12 X 115 LONG	7.55
F-175-1	175	192	210	4 X M12 X 115 LONG	9.60
F-200-1	200	218	235	4 X M12 X 115 LONG	8.70
F-225-1	225	230	247	6 X M12 X 115 LONG	11.80
F-225-2	225	250	267	6 X M12 X 115 LONG	13.50
F-250-1	250	265	280	6 X M12 X 115 LONG	13.90
F-250-2	250	272	289	6 X M12 X 120 LONG	13.60
F-300-1	300	315	332	6 X M12 X 135 LONG	15.00
F-300-2	300	322	339	6 X M12 X 135 LONG	15.50
F-300-3	300	332	349	6 X M12 X 135 LONG	16.60
F-350-1	350	374	391	8 X M14 X 160 LONG	36.00
F-400-1	400	417	437	8 X M14 X 160 LONG	38.00
F-450-1	450	480	500	10 X M14 X 160 LONG	44.00
F-500-1	500	526	546	10 X M14 X 160 LONG	49.00
F-600-1	600	630	650	10 X M14 X 160 LONG	58.00