

SIGMA - your fitting choice

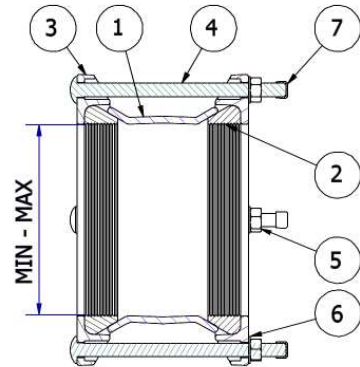

W - Range Couplings

Materials & Coatings



W - Range Couplings - Parts List

ITEM	DESCRIPTION	MATERIAL	SPECIFICATION
1	BODY CASTING	420/12 CAST S.G.IRON	WRAS APPROVED POWDER COATING
2	2 x GASKETS	EPDM ELASTOMER	EPDM ELASTOMER TO B.S.6920
3	2 X END RING CASTING	420/12 CAST S.G.IRON	WRAS APPROVED POWDER COATING
4	4 X M12 ADJUSTING BOLT	GRADE 8.8 STEEL	DACROMATE PLATED
5	4 X HEXAGON NUT	HEXAGONAL NUT	DACROMATE PLATED
6	4 X WASHER	FLAT WASHERS	DACROMATE PLATED
7	4 X THREAD CAP	NYLON MOULDING	NATURAL FINISH

W - Range - RANGE DIMENSIONS

MODEL No.	DN	MIN O/D	MAX O/D	No. BOLTS & SIZE	WGT (kg)
C-40-1	40	48	60	2 X M12 X 175 LONG	2.86
C-50-1	50	59	72	2 X M12 X 175 LONG	3.11
C-65-1	65	72	85	3 X M12 X 175 LONG	3.60
C-80-1	80	88	103	4 X M12 X 175 LONG	4.22
C-100-1	100	105	122	4 X M12 X 175 LONG	4.80
C-100-2	100	109	128	4 X M12 X 175 LONG	5.05
C-125-1	125	125	140	4 X M12 X 175 LONG	5.50
C-125-2	125	132	146	4 X M12 X 175 LONG	5.91
C-125-3	125	138	153	4 X M12 X 175 LONG	5.76
C-150-1	150	155	175	4 X M12 X 200 LONG	7.50
C-150-2	150	159	182	4 X M12 X 200 LONG	7.70
C-175-1	175	192	210	4 X M12 X 200 LONG	9.20
C-200-1	200	218	235	4 X M12 X 220 LONG	9.95
C-225-1	225	230	247	5 X M12 X 220 LONG	14.35
C-225-2	225	250	267	5 X M12 X 220 LONG	14.50
C-250-1	250	265	280	6 X M12 X 220 LONG	15.00
C-250-2	250	272	289	6 X M12 X 220 LONG	16.50
C-300-1	300	315	332	8 X M12 X 220 LONG	23.50
C-300-2	300	322	339	8 X M12 X 220 LONG	23.80
C-300-3	300	332	349	8 X M12 X 220 LONG	24.00
C-350-1	350	374	391	8 X M14 X 240 LONG	35.00
C-400-1	400	417	437	8 X M14 X 240 LONG	40.00
C-450-1	450	480	500	10 X M14 X 240 LONG	45.00
C-500-1	500	526	546	10 X M14 X 240 LONG	53.00
C-600-1	600	630	650	10 X M14 X 240 LONG	66.00

