

# SIGMA - your fitting choice

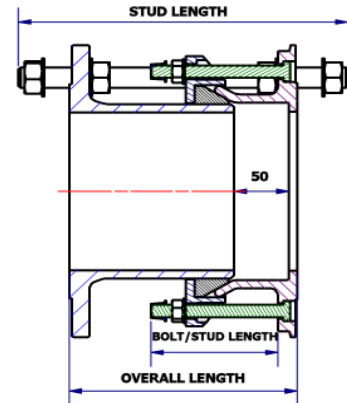

## Dismantling Joint



### Materials & Coatings

SCP DISMANTLING JOINTS - PN 16			
ITEM	DESCRIPTION	MATERIAL	SPECIFICATION
1	FLANGE BODY CASTING	DUCTILE IRON TO BS EN 1563-EN-GJS 450-10	WRAS APPROVED POWDER COATING
2	END RING CASTING	DUCTILE IRON TO BS EN 1563-EN-GJS 450-10	WRAS APPROVED POWDER COATING
3	FLANGE SPIGOT CASTING	DUCTILE IRON TO BS EN 1563-EN-GJS 450-10	WRAS APPROVED POWDER COATING
4	*COMPRESSION BOLTS/STUDS	CARBON STEEL GRADE 8.8 BZP	BZP & BLACK PLASCOAT COATED AS STD
5	*COMPRESSION NUTS & WASHERS	CARBON STEEL GRADE 8.8 BZP	BZP & BLACK PLASCOAT COATED AS STD
6	RESTRAINT STUDS	CARBON STEEL GRADE 8.8 OR OTHER AS SPECIFIED	COATED TO CUSTOMER SPECIFICATION
7	* RESTRAINT NUTS & WASHERS	STAINLESS STEEL GRADE A2	NATURAL FINISH
8	COMPRESSION GASKET	EPDM OR NITRILE TO BS 6920	WRAS APPROVED MATERIAL

\* - ALTERNATIVE OPTIONS TO THE ABOVE ARE AVAILABLE ON REQUEST

DISMANTLING JOINT - DIMENSIONS					
MODEL No.	DN	PN	O/ALL LEN	No. STUDS & LEN	No. BOLTS/STUDS & LEN
DJ-50-1	50	16	200	2 X M16 X 290 LONG	2 X M12 X 115 LONG
DJ-80-1	80	16	200	2 X M16 X 290 LONG	4 X M12 X 115 LONG
DJ-100-1	100	16	206	2 X M16 X 290 LONG	4 X M12 X 115 LONG
DJ-150-1	150	16	206	2 X M20 X 300 LONG	4 X M12 X 115 LONG
DJ-200-1	200	16	206	2 X M20 X 300 LONG	6 X M12 X 115 LONG
DJ-250-1	250	16	218	2 X M24 X 340 LONG	6 X M12 X 115 LONG
DJ-300-1	300	16	236	4 X M24 X 340 LONG	6 X M12 X 115 LONG
DJ-350-1	350	16	270	4 X M24 X 380 LONG	8 X M14 X 150 LONG
DJ-400-1	400	16	270	4 X M24 X 400 LONG	8 X M14 X 150 LONG
DJ-450-1	450	16	270	4 X M24 X 400 LONG	10 X M14 X 150 LONG
DJ-500-1	500	16	270	4 X M30 X 410 LONG	10 X M14 X 150 LONG
DJ-600-1	600	16	280	4 X M33 X 440 LONG	10 X M14 X 150 LONG